

A decorative graphic in the top left corner shows a close-up of grey tactile paving tiles with a grid of raised circular bumps. A person's feet wearing grey sneakers are visible walking on the tiles.

Development Application **ACCESS REPORT**

Reference Number: 22440

Client: MONIQUE BARAKAT

Site Address: 14 Windermere Avenue, Northmead NSW



Vista Access Architects Pty. Ltd.

www.accessarchitects.com.au

admin@accessarchitects.com.au

PO Box 353, Kingswood NSW 2747

ABN: 82124411614

Executive Summary and Design Compliance Statement

This Access Compliance Report is to accompany a Development Application (DA) for the development proposed at **14 Windermere Avenue, Northmead NSW**

The development is within City of Parramatta Council LGA and proposes a **New Building**.

The development proposes a Childcare centre with 1 accessible parking space.

The development has building classification as detailed below:

- Class 7a (car park)
- Class 9b (assembly building, school)

This report is based on the relevant components of:

- Building Code of Australia (BCA) 2019, Volume 1- Performance requirements of DP1, DP2, DP8, DP9, EP3.4, FP2.1 and Parts D2, D3, E3 and F2 (where applicable)
- Disability (Access to Premises-Building) Standards 2010 (henceforth referred to as APS)
- AS1428.1-2009 Part 1: General requirements for access, including any amendments
- AS1428.4.1-2009 Part 4.1: TGSIs (Tactile ground surface indicators), including any amendments
- AS2890.6-2009 Part 6: Off-street parking for people with disabilities.
- AS1735-1999 Lift types included in the BCA including Part 12: Facilities for persons with disabilities

The assessment of the proposed development has been undertaken to the extent necessary to issue DA consent under the Environmental Planning and Assessment Act. The proposal achieves the spatial requirements to provide access for people with a disability and it is assumed that assessment of the detailed requirements such as assessment of internal fit-out, details of stairs, ramps and other features will occur at CC (Construction Certificate) stage.

By compliance with the recommendation in this report, the development complies with the requirements of Access Code of Disability (Access to Premises-Building) Standards 2010, and the Disability Access relevant sections of Building Code of Australia 2019.

The information contained in this statement is true and accurate to the best of our knowledge. Our qualifications and accreditations are listed below.

Assessed by



Trin Woo

Access Consultant

ACAA Affiliate Membership number 776

Peer reviewed by



Farah Madon

Accredited Access Consultant and LHA Assessor

ACAA Accredited Membership number 281

Qualified- Diploma in Access Consulting

LHA Assessor Licence number 10032

Vista **Access Architects** Pty. Ltd.

Relevant Dates:

Fee proposal, number FP-22975 dated **14-11-2022**. Fee proposal was accepted by Client on **14-11-2022**

Assessed Drawings:

The following drawings by Janssen Designs have been assessed for compliance.

Drawing no	Issue	Date	Details
A000	A	15-06-2022	Lower Ground Floor Plan
A000	A	15-06-2022	Ground Floor Plan
A000	A	15-06-2022	First Floor Plan

Document Issue:

Issue	Date	Details
Draft 1	18-11-2022	Issued for Architect's review
A	22-11-2022	Issued for DA

Limitations and Copyright information:

This report is based on discussions with the project architect and a review of drawings and other relevant documentation provided to us. No site visit was undertaken for the purposes of this report.

This assessment is based on the provided drawings and not based on constructed works; hence the assessment will provide assurance of compliance only if all the recommendations as listed in this report are complied with and constructed in accordance with the requirements of the current BCA, AS1428.1, AS2890.6 and other latest, relevant standards and regulations applicable at the time of construction.

Assessment is based on classification/use of the building. If the class of the building changes to any other building class, this access report will have to be updated accordingly.

Unless stated otherwise, all dimensions mentioned in the report are net (CLEAR) dimensions and are not to be reduced by projecting skirting, kerbs, handrails, lights, fire safety equipment, door handles less than 900mm above FFL (finished floor level) or any other fixtures/fit out elements. When we check drawings, we assume that the dimensions noted are CLEAR dimensions and therefore the Architect / Builder shall allow for construction tolerances.

Only some numerical requirements from relevant AS (Australian Standards) have been noted in the report and for further details and for construction purposes refer to the latest relevant AS.

This report and all its contents including diagrams are a copyright of Vista Access Architects Pty Ltd (VAA) and can only be used for the purposes of this specific project. Copy-pasting diagrams from this report to Architectural plans will constitute copyright infringement.

This report does not assess compliance matters related to WHS, Structural design, Services design, Parts of DDA other than those related to APS or Parts of BCA or Parts of AS other than those directly referenced in this report. VAA gives no warranty or guarantee that this report is correct or complete and will not be liable for any loss arising from the use of this report. We will use our best judgement regarding LHA assessments. However, we are not to be held responsible if another licenced LHA assessor comes to a different conclusion about compliance, certification, or allocation of a particular Quality mark to us as several items in LHA are subject to interpretation.

We have no ability to check for slip resistance of surfaces. All wet areas, parking areas, pavement markings shall have the appropriate slip resistance for the location. We also have no ability to check for wall reinforcements once the walls have already been constructed. The builder shall take full responsibility that the requirements listed in this report are met and the construction and slip resistance shall be as per requirements of AS1428.1/ AS4299 / AS2890.6/ AS3661/ AS4586/ HB197/ HB198 and any other applicable regulation and Australian Standard

Hierarchy of Access-related Legislation and Standards

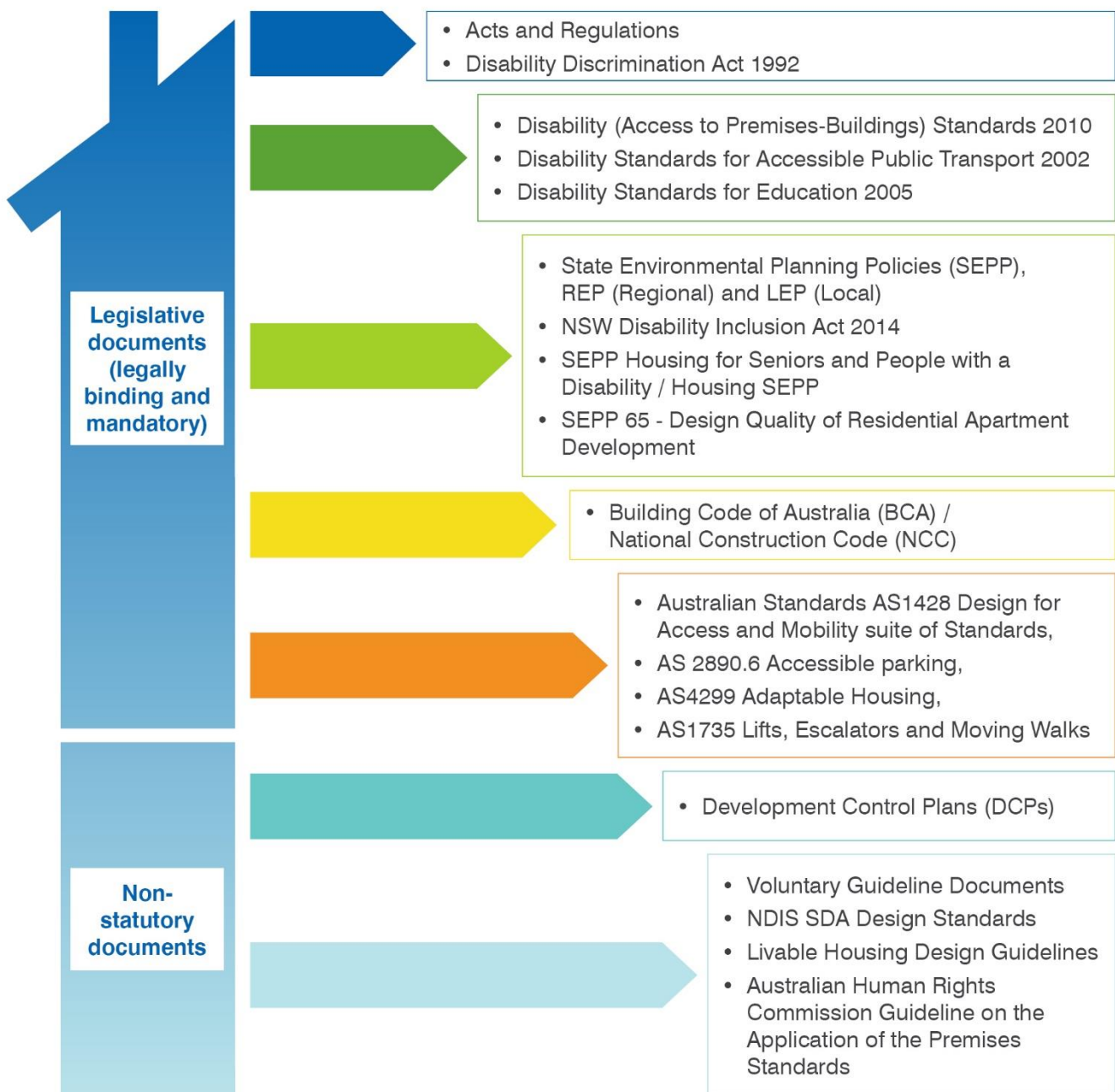

The Federal Disability Discrimination Act 1992 (DDA) provides protection for everyone in Australia against discrimination based on disability. Section 32 of the DDA focuses on the provision of equitable and dignified access to services and facilities for people with mobility, sensory and cognitive disabilities.

Disability discrimination happens when people with a disability and their relatives, friends, carers, co-workers or associates are treated less fairly than people without a disability.

Compliance with Access to Premises Standards give certainty to building certifiers, building developers and building managers that, if access to (new parts) of buildings is provided in accordance with these Standards, the provision of that access, to the extent covered by these Standards, will not be unlawful under the DDA. This however applies only to the new building or new parts of an existing building and its affected part. All areas outside the scope of these areas are still subject to the DDA. We cannot guarantee or certify for DDA compliance because DDA compliance can only be assessed by the Courts.

Scope of DDA extends beyond the building fabric and also includes furniture and fittings.

Compliance assessment with Access related requirements of BCA and Disability (Access to Premises-Building) Standards 2010 (APS)

Development consists of new building/s and therefore compliance is required to full development

BCA 2019 Part D3 Access for People with a Disability BCA D3.1 General building Access requirements

Requirement

Class 7a - Covered car park.

- To and within any level containing accessible carparking spaces.

Compliance Complies

Comments

Access has been provided to all levels containing Accessible carparking spaces.
All Accessway widths are to be a minimum of 1M clear (measured from skirting to skirting) with vertical clearance of at least 2M
Details to be verified at CC stage of works.

Requirement

Class 9b - Schools and early childhood centres.

- To and within all areas that are normally used by the occupants.

Compliance Complies

Comments

- Access has been provided to and within all areas required to be accessible.
- Access has been provided to common use garbage storage rooms
- All common use accessway widths are to be a minimum of 1M clear measured from skirting to skirting (increases to comply with door circulation spaces where doorways provided) with vertical clearance of at least 2M

Advisory note for any common use kitchen or BBQ areas (where provided)

- It is recommended that kitchen / BBQ areas could be made partially accessible by providing a workspace of 900mm width next to the sink/cooktop/BBQ as vacant space (without cabinetry under the bench top)
- Provide long lever tap to sink with and handle and water source being within 300mm from the front edge of the benchtop.
- Provide 1 double GPO within 300mm from the front edge of the benchtop.

Advisory note for Reception tables (where provided)

- It is recommended that a lower section for a width of 900mm could be provided to be able to be used by a person in a wheelchair. Height of the FFL (finished floor level) to the top of the table to be 850 +/-20mm and height of clearance beneath the unit from the FFL to be 820 +/-20mm

Details to be verified at CC stage of works.

BCA 2019 Part D3.2 Access to buildings

Requirement

Accessway is required from:

- Main pedestrian entry at the site boundary for new buildings.
- Any other accessible building connected by a pedestrian link.
- Accessible car parking spaces.

Compliance

Capable of compliance

Comments

- Access by means of 1:20 grade walkways have been provided from the main pedestrian entry at the site boundary.
 - Access has been provided from accessible car parking spaces by means of accessible pathways
- Details to be verified at CC stage of works.

Requirement

Common use External Walkway / Pedestrian access requirements as per AS1428-2009:

- Accessible path of travel to have a gradient no steeper than 1 in 20 and a cross fall no steeper than 1:40 (1:33 for bitumen).
- For 1:20 grade walkways, landings are required every 15M.
- The floor surface abutting the sides of the walkway to be provided with a firm and level surface (of a different material) at the same level and grade of the walkway and extend horizontally for a minimum of 600mm unless one of the following is provided: kerb, kerb-rail and handrail or wall of minimum 450mm height.
- Curved walkways to be min 1500mm width with crossfall towards the centre of curvature.
- At 90-degree bends in pathways provide a 1500mmx1500mm space with maximum 500mm splay permitted at internal corner.

Compliance

Complies with spatial requirements

Comments

At CC stage the 1:20 walkway to have landings every 15M intervals

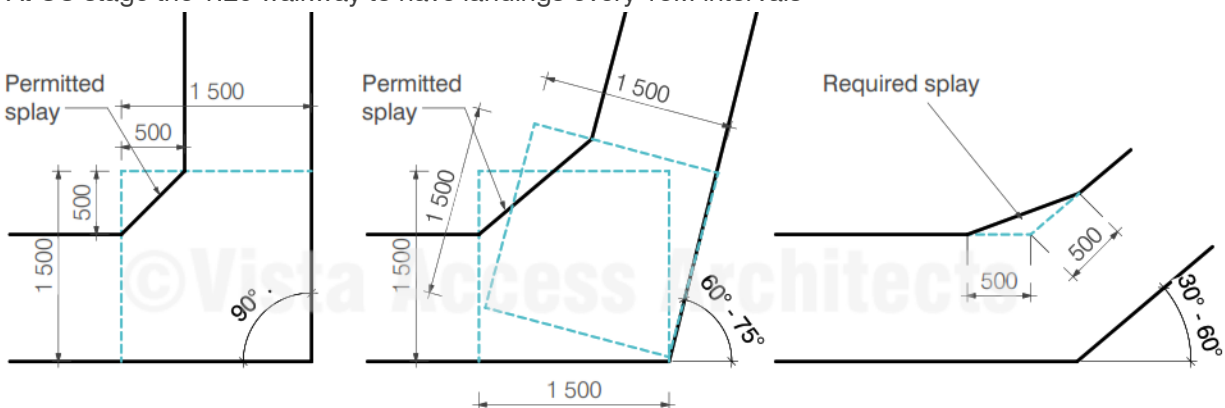

Details to be verified at the CC stage of works.

[Image description: Spatial requirements of walkways with bends as per AS1428.1]

Requirement

Common use floor or ground surfaces

- Use slip-resistant surfaces
- The texture of the surface is to be traversable by people who use a wheelchair and those with an ambulant or sensory disability.
- Abutment of surfaces is to have a smooth transition.
- Construction tolerances to be +/- 3mm vertical or +/-5mm, provided the edges have a bevelled or rounded edge (See diagrams below)

Grates if used in the accessible path of travel are required to comply with the following:

- Circular openings maximum of 13 mm in diameter
- Slotted openings maximum of 13 mm wide and be oriented so that the long dimension is transverse to the dominant direction of travel

Where slotted openings are less than 8 mm, the length of the slots may continue across the width of paths of travel

Compliance Complies with spatial requirements

Comments

Details to be verified at the CC stage of works.

Requirement

Accessway is required through:

- Principal pedestrian entry; and
- Not less than 50% of all pedestrian entrances; and
- In building with floor area over 500m², a non-accessible entry must not be located more than 50M from an accessible entry.

Compliance Complies

Comments

The building has only 1 pedestrian entry, which has been designed to be accessible.

Requirement

All common use doorways to comply with AS1428.1.

Where accessible pedestrian entry has Multiple doorways:

- At least 1 to be accessible if 3 provided
- At least 50% to be accessible, if more than 3 provided
- Where doorway has multiple leaves, at least 1 leaf is to have clear opening of 850mm (excluding automatic doors)

Doorway requirements

- All common use doorways in the development within accessible path of travel (other than doorways non-accessible sanitary facilities) to have a clear opening of at least 850mm with appropriate door circulation spaces in accordance with AS1428.1. In case of multiple leaf doorways, at least 1 operable leaf is required to provide a clear opening of 850mm with the door circulations spaces as per AS1428.1.
- Ambulant toilet cubicle door to have a clear door opening of 700mm.
- Space required for door circulation spaces to have a maximum floor grade of 1:40 (doorway threshold ramps are permitted within the circulation space).

- Door thresholds are to be level, or they can incorporate a doorway threshold ramp with a maximum grade of 1:8, for maximum rise of 35mm and a maximum length of 280mm and located within 20mm of the door leaf, with edges to be tapered or splayed at a minimum of 45° where it does not abut a wall.
- Sliding doorways to be provided with recessed floor tracks to enable flush transition from the inside of the building.
- Distance between successive doorways in airlocks to be 1450mm which is measured when the door is in open position in case of swinging doors.
- Door hardware including door handles, door closers and the in-use indicators / snibs in accessible and ambulant toilets are required to comply with requirements of AS1428.1.
- Luminance contrast requirements to doorways and other glazed areas to comply with AS1428.1

Compliance Complies with spatial requirements

Comments

Details to be verified at the CC stage of works.

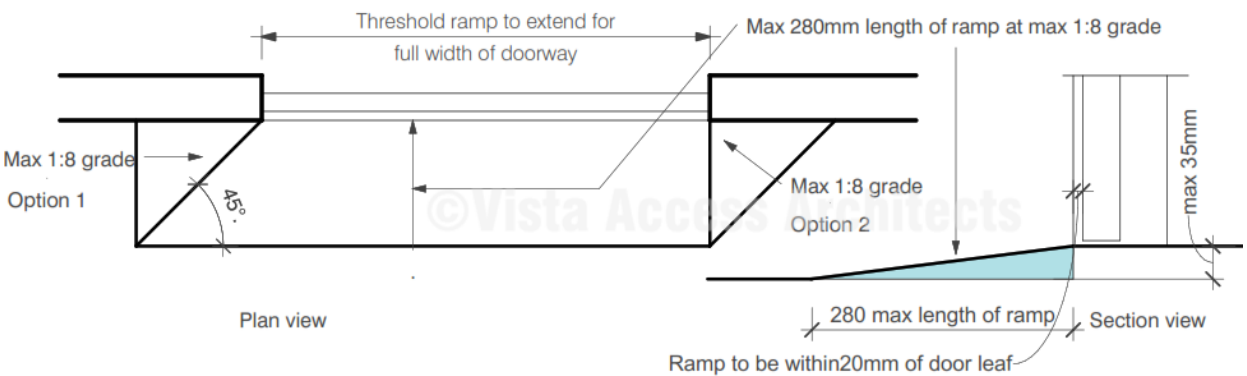

[Image description: Diagram showing requirements for door circulation spaces and door threshold requirements as per AS1428.1]

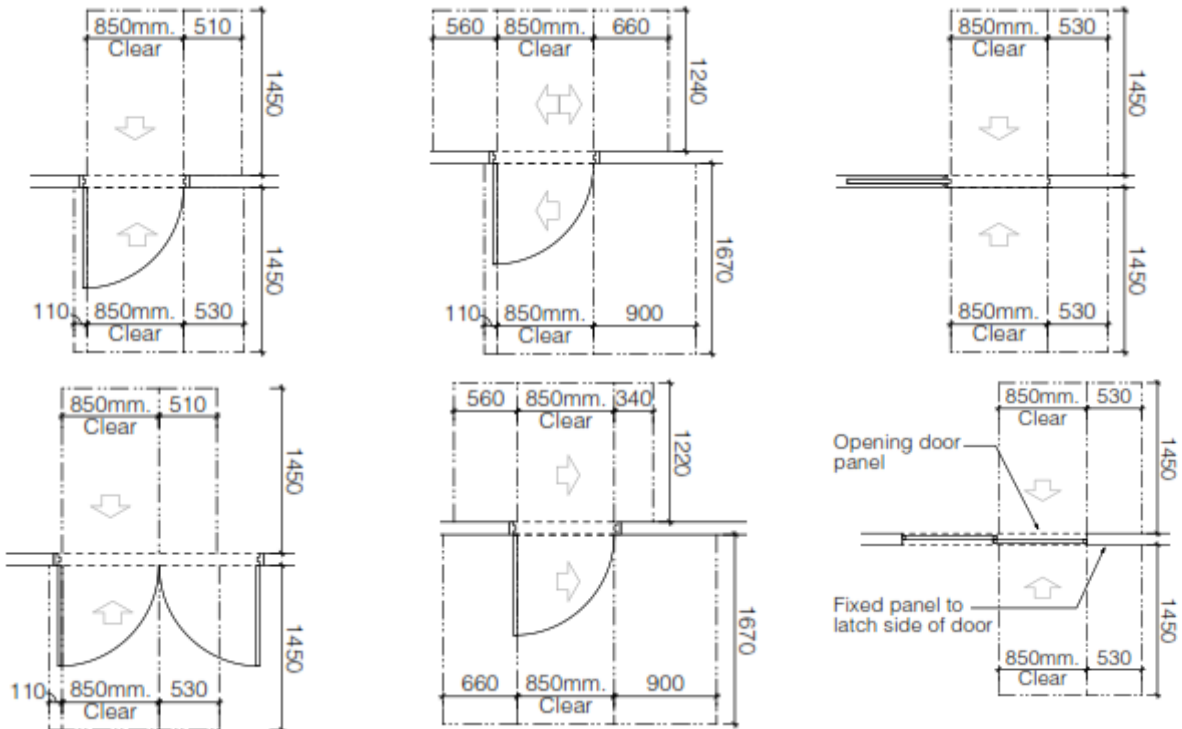

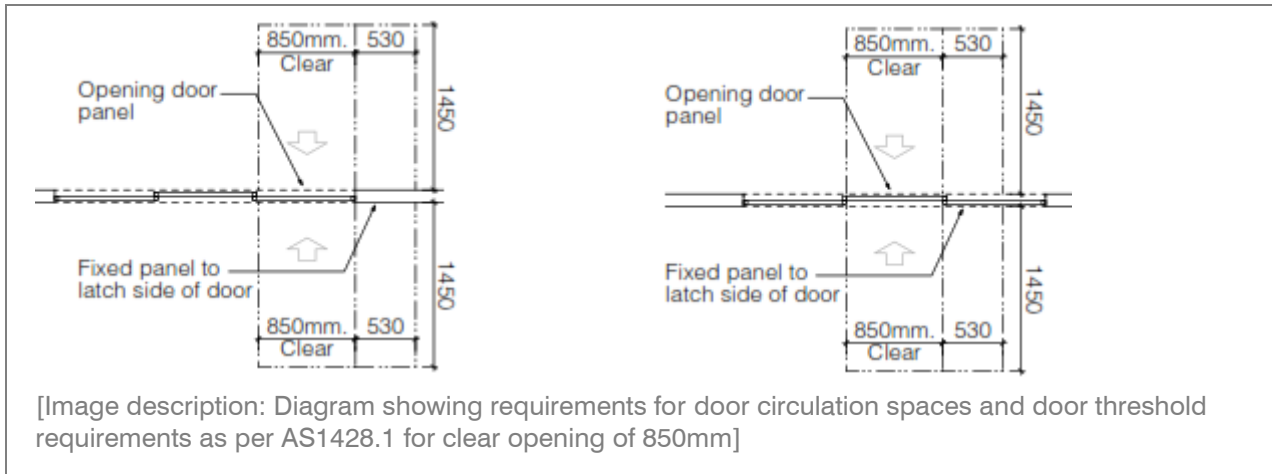

BCA 2019 Part D3.3 Parts of buildings required to be accessible

Requirement

Every common use **Ramp** with grades steeper than 1:20 and less than or equal to 1:14 (excluding fire-isolated ramp) is to be compliant with Clause 10 of AS1428.1

Compliance N/A

Comments

No 1:14 ramps have been identified in the development.

Requirement

Step ramp if provided in common use areas is to be compliant with AS1428.1-2009 and NCC/BCA

Compliance N/A

Comments

No step ramps have been identified in the development.

Requirement

Kerb ramp if provided in common use areas is to be compliant with AS1428.1-2009

Compliance N/A

Comments

No kerb ramps have been identified in the development.

Requirement

Every **Stairway** in common use areas (excluding fire-isolated stairway) is to be compliant with:

- Clause 11 of AS1428.1-2009 (including but not limited to opaque risers, handrails on both sides including appropriate handrail extensions between 1M clear width and compliant nosing strips).
- Diameter of handrails to be between 30mm-50mm and located not less than 50mm from adjacent walls with no obstructions to top 270° arc.
- Slip resistance to comply with BCA Table D2.14 when tested in accordance with AS4586.

Compliance

Complies with spatial requirements

Comments

Where non-fire-isolated stairways have been provided, the features of the stairway will be assessed with the requirements of AS1428.1-2009 at the CC stage of works

Note: In some cases, the stairway from the basement to the ground floor level is considered to be non-fire-isolated, in which case full compliance will be required as per AS1428.1-2009. Verify with the BCA consultant if this is the case.

Note: For stairways with 90° to 180° turns at landings, in order for the handrails to comply with the consistent height requirement, the risers have to be offset at the mid-landings so that no vertical sections are created in the handrails. This applies to both non- fire-isolated and fire-isolated stairways.

Option A- extend handrail by 1 tread at midlanding Option B- offset first riser going up at midlanding

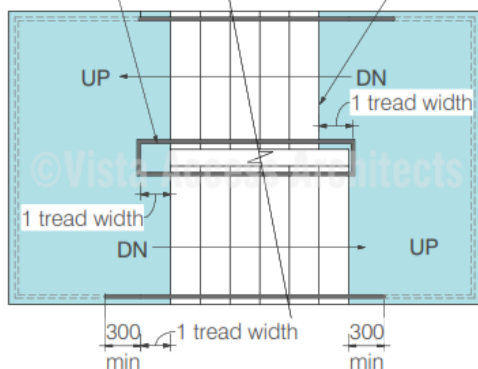

[Image description: Diagram showing the requirements of a non-fire-isolated stairway as per AS1428.1]

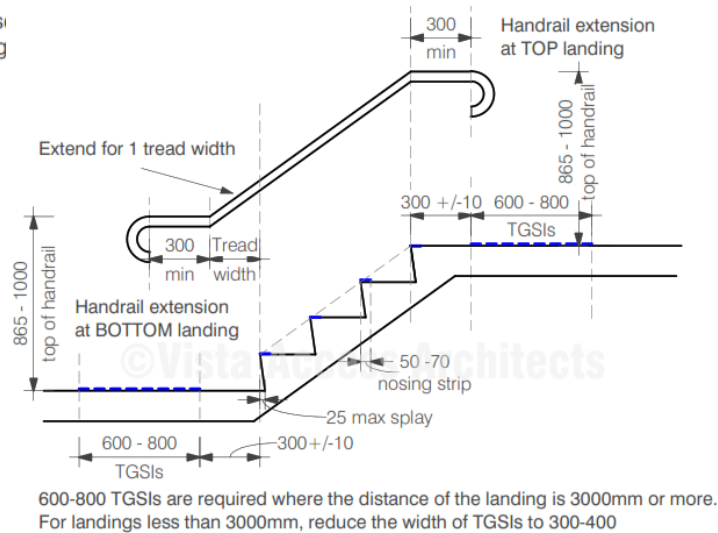

Requirement

Every **Fire-isolated Stairway** is to be compliant with AS1428.1-2009 in the following aspects:

- Handrail on one side (requirement under D2.17) with 1M clear space. Handrail extensions are not required however since the handrails cannot have any vertical sections and since handrail is required to be at a consistent height throughout the stairway including at landings, it may be essential to either provide handrail extensions or offset first riser going up at mid landings to achieve this at 90° to 180° turns. Handrails to both sides of the stairway are required if the total width of the stairway is 2M or more.
- Diameter of handrails to be between 30mm-50mm and located not less than 50mm from adjacent walls with no obstructions to top 270° arc.
- Slip resistance to comply with BCA Table D2.14 when tested in accordance with AS4586.

Compliance

N/A

Comments

No fire-isolated stairways have been identified in the development

Requirement

Nosing for common use fire-isolated and non-fire-isolated stairways require the following:

- Each tread to have a nosing strip between 50mm-75mm depth (of any one colour) for the full width of the stair, which can be setback for a maximum of 15mm from the front of the nosing.
- Multiple strips making up the 50mm-75mm depth is NOT permitted.
- This strip is to have a minimum luminance contrast of 30% to the background and to comply with any change in level requirements if attached on the treads.
- Where the nosing strip is not set back from the front of the nosing then any area of luminance contrast shall not extend down the riser more than 10mm
- Slip resistance to comply with BCA Table D2.14 when tested in accordance with AS4586.

Compliance Complies with spatial requirements

Comments

Detailed features of the nosing strips will be assessed with the requirements of AS1428.1 at the CC stage of works.

Requirement

Slip resistance requirements as per BCA

BCA Table D2.14 Slip –resistance requirements when tested in accordance with AS4586:

Application	Surface conditions	
	Dry	Wet
Ramp steeper than 1:14	P4 or R11	P5 or R12
Ramp steeper than 1:20 but not steeper than 1:14	P3 or R10	P4 or R11
Tread or landing surface	P3 or R10	P4 or R11
Nosing or landing edge strip	P3	P4

HB 197/ HB198 An introductory guide to the slip resistance of pedestrian surface materials provides guidelines for the selection of slip-resistant pedestrian surfaces

Compliance Complies with spatial requirements

Comments

For Slip resistance of surfaces the builder is required to provide a Certificate stating that the Slip resistance of the surfaces comply with the above listed requirements when tested as per AS4586 at CC stage of works.

Requirement

Every **Passenger lift** is to comply with the requirements of BCA E3.6.

Compliance Complies with spatial requirements

Comments

This has been assessed further in the report in the Lifts section. Refer to Lifts section.

Requirement

Passing spaces requirement

It is a requirement to provide passing spaces in common use accessways complying with AS1428.1 at maximum 20 M intervals, where a direct line of sight is not available. Space required is 1800x2800mm (in the direction of travel). Chamfer of 400x400mm is permitted at corners.

Compliance N/A

Comments

There are no accessways over 20M lengths in the development where a direct line of sight is not available.

Requirement

Turning spaces requirement

It is a requirement to provide turning spaces in common use accessways complying with AS1428.1-2009 within 2M of the end of accessways where it is not possible to continue travelling and at every 20M intervals. CLEAR Space required is 1540mmx2070mm in the direction of travel (measured from skirting to skirting).

Compliance Complies with spatial requirements

Comments

- Adequate turning spaces have been provided with minimum common use passageway widths being 1540mm clear or alternatively a space of 1540mmx2070mm provided at or within 2M of the end of the passageway.
- The passageway is more than 20M long and therefore a space of 1540mmx2070mm provided at maximum 20M intervals.
- A space of 1540mmx2070mm is also required / provided in front of all passenger lift doors.

Details to be verified at CC stage of works.

Advisory note

Where furniture layouts have been decided in developments, ensure that 1M clear space is available around all furniture and that a turning space of 1540mmx2070mm (in the direction of travel) is provided in areas where travel is no longer possible and a person in a wheelchair would be required to make a 180° turn

Requirement

Carpet specifications

Carpet if used in areas required to be accessible are to be provided with pile height or thickness not more than 11mm and carpet backing not more than 4mm bringing the total height to a maximum of 15mm.

Compliance Complies with spatial requirements

Comments

Applies only if carpets are provided in the common use areas
Details to be verified at CC stage of works.

BCA 2019 Part D3.4 Exemption

Requirement

Access is not required to be provided in the following areas:

- Where access would be inappropriate because of the use of the area
- Where area would pose a health and safety risk
- Any path which exclusively provides access to an exempted area

Compliance

For information only

Comments

Areas such as lift machine rooms, fire services room, commercial kitchens etc. in the development are exempted from providing access under this clause due to WHS concerns.

Where a caretaker is provided in the development, the toilet provided exclusively for use by the caretaker can be excluded from providing access based on the provisions in this clause.

BCA 2019 Part D3.5 Accessible Carparking

Requirement

Class 9b

- School - 1 Accessible car parking space per 100 spaces provided
- Other assembly building - 1 Accessible car parking space per 50 spaces provided and then additional 1 Accessible car parking space per additional 100 spaces provided

Compliance

Complies

Comments

Total number of Accessible parking spaces required / provided in the development = 1

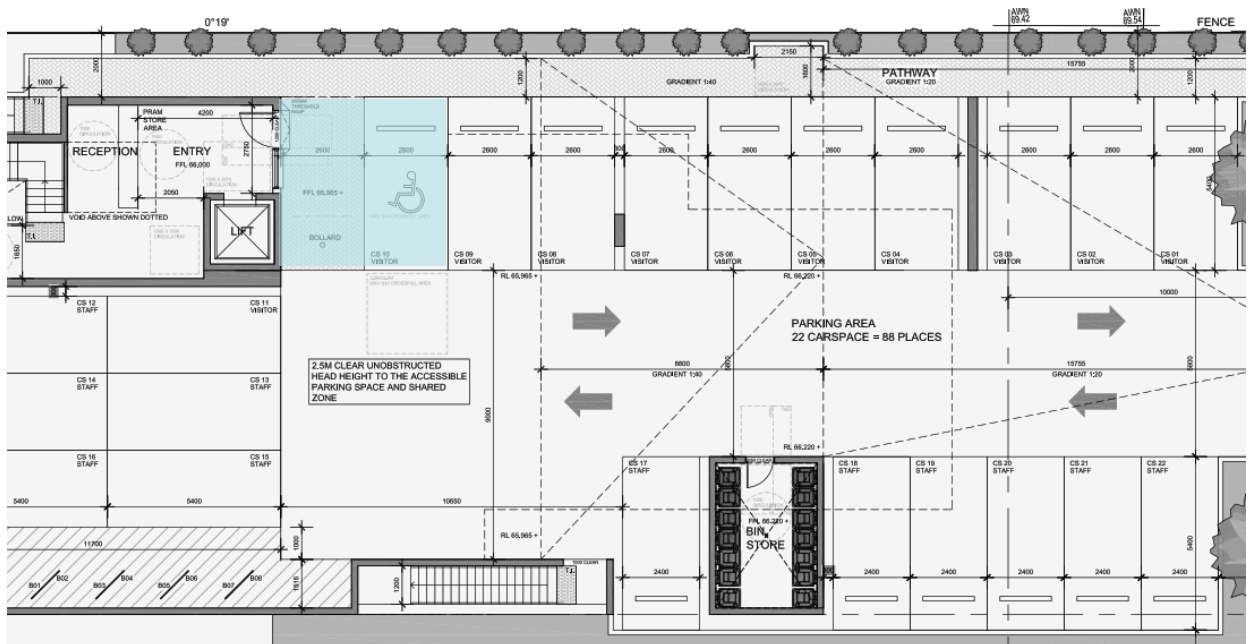

[Image description: Plan of Ground Level above shows the provision of Accessible parking spaces]

AS2890.6-2009 requirements for Accessible car parking space

Requirement

- Dedicated space 2.4Mx5.4M, Shared space 2.4Mx5.4M at the same level
- Slip resistant flooring surface with maximum fall 1:40 in any direction or maximum 1:33 if bituminous and outdoors.
- Central Bollard in shared space at 800 +/-50mm from entry point.
- Pavement marking in dedicated space by means of access symbol between 800mm-1000mm high placed on a blue rectangle of maximum 1200mm and between 500mm-600mm from its entry point (marking not required where allocated to an Adaptable unit).
- Minimum headroom of 2.2M at entrances and 2.5M is required over shared space as well as dedicated spaces.
- Non-trafficked area of the shared space to have marking strips at 45°, 150-200mm wide at 200mm-300mm spaces (not required where driveways are used as shared spaces)
- The pavement marking shall have the appropriate slip resistance for the location. This requirement is to be added to the project specifications to ensure compliance.

Compliance

Complies with spatial requirements

Comments

Details to be verified at CC stage of works.

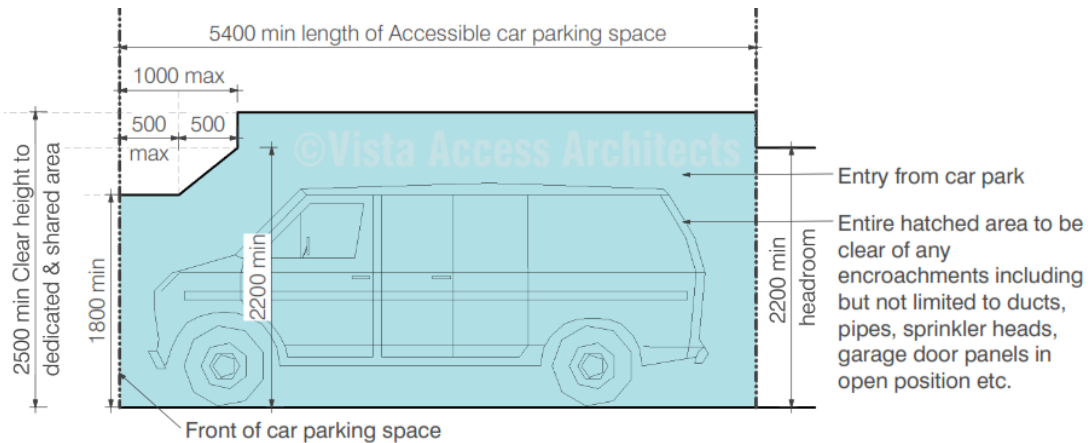

150-200 wide yellow diagonal stripes with spaces 200-300 between stripes at 45 +/- 10°

[Image description: Diagram showing spatial requirements of AS2890.6 including line marking, symbol and bollard requirements]

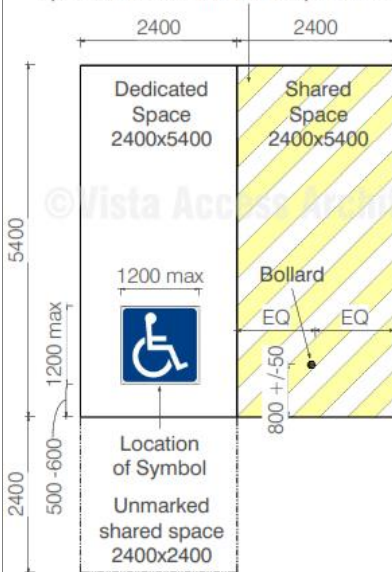

BCA 2019 Part D3.6 Signage

Requirement

Braille and Tactile signage are required to identify Accessible Sanitary facilities



[Image description: Diagram to help choose the correct signage based on LH/RH transfer]

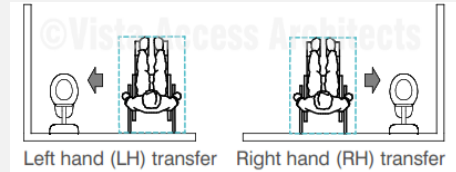

International sign of access is required to signage to all accessible sanitary facilities (excluding SOUs within Class 1b or Class 3) and signage is required to identify if facility is for LH (left hand transfer) or RH (right hand transfer)

Compliance

Complies with spatial requirements

Comments

Signage selections generally take place at CC stage of works. Selection and location of signage as specified above will lead to compliance. Details of selected signage to be verified at CC stage of works.

Requirement

Braille and Tactile signage are required immediately outside an airlock or doorway that leads to separate male, female and accessible toilets.

Compliance

N/A

Comments

N/A

Requirement

Braille and Tactile signage are required to identify Ambulant Sanitary facilities

Compliance

N/A

Comments

No ambulant sanitary facilities have been identified in the development.

Requirement

Braille and Tactile signage is required to identify Hearing Augmentation

Compliance

N/A

Comments

Hearing augmentation is not provided since there is no inbuilt amplification system identified in the development.

Requirement

Braille and Tactile signage is required to identify a Fire exit door required by E4.5 by stating the 'Exit' and 'Level', followed by either the floor level number or floor level descriptor or a combination of both of the above and located on the side that faces a person seeking egress

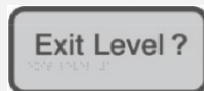

[Image description: Image of Signage The "?" shown in image is to be replaced with the floor level where the door is located]

Compliance Complies with spatial requirements

Comments

Signage selections generally take place at CC stage of works. Selection and location of signage as specified above will lead to compliance. Details of selected signage to be verified at CC stage of works.

Requirement

Signage is required to a non-accessible pedestrian entrance

Compliance N/A

Comments

The development has only 1 entry which has been designed to be accessible.

Requirement

Signage is required where a bank of sanitary facilities is not provided with an accessible unisex sanitary facility.

Compliance N/A

Comments

N/A

Requirement

Signage is required where a bank of sanitary facilities is not provided with an accessible unisex sanitary facility.

Directional signage incorporating the international symbol of access as per AS1428.1 must be placed at the location of the sanitary facilities that are not accessible, to direct a person to the location of the nearest accessible unisex sanitary facility.

Compliance N/A

Comments

N/A

Requirement

Directional signage: In a building subject to F2.9, directional signage complying with Specification D3.6 must be provided at the location of each—

- i. bank of sanitary facilities; and
- ii. accessible unisex sanitary facility, other than one that incorporates an accessible adult change facility, to direct a person to the location of the nearest accessible adult change facility within that building.

Compliance N/A

Comments

N/A

Requirement

Signage is required to be as per Specification D3.6 Braille and Tactile Signs

This includes location of signage, specifications in regard to braille and tactile characters, luminance contrast and lighting.

Compliance Complies with spatial requirements

Comments

Signage selections generally take place at CC stage of works. Selection and location of signage as specified above will lead to compliance. Details of selected signage to be verified at CC stage of works.

BCA 2019 Part D3.7 Hearing Augmentation

Requirement

Hearing Augmentation is only required where an inbuilt amplification system (other than emergency) is installed in a Class 9b building, or in an auditorium, conference / meeting room or a reception area where a screen is used.

Compliance N/A

Comments

No areas with provision of inbuilt amplification have been identified on plans and hence no hearing augmentation requirements apply to this development.

If inbuilt amplification system is proposed in the development, then hearing augmentation is to be provided.

BCA 2019 Part D3.8 Tactile ground surface indicators (TGSIs)

Requirement

TGSIs are required when approaching:

- Stairways other than fire-isolated stairways.
- Escalators / passenger conveyor / moving walk.
- Ramp (other than fire-isolated ramps, kerb ramps, step ramps or swimming pool ramps).
- Under an overhead obstruction of <2M if no barrier is provided.
- When accessway meets a vehicular way adjacent to a pedestrian entry (if no kerb / kerb ramp provided at the location).

Compliance is required with AS1428.4.1 including Luminance contrast and slip resistance requirements for all TGSIs. TGSIs to extend for full width i.e., handrail to handrail.

Compliance

Complies with spatial requirements

Comments

TGSI selections generally take place at CC stage of works. Selection of TGSIs as specified will lead to compliance and these selection details are to be verified at CC stage of works.

BCA 2019 Part D3.11 Limitations on Ramps

Requirement

On an accessway:

- A series of connected ramps must not have a combined vertical rise of more than 3.6M;
- And a landing for a step ramp must not overlap a landing for another step ramp or ramp.

Compliance

N/A

Comments

No ramps have been identified in the development

BCA 2019 Part D3.12 Glazing on Accessways

Requirement

Glazing requirements:

- Where there is no chair rail, handrail or transom, all frameless or fully glazed doors, sidelights and any glazing capable of being mistaken for a doorway or opening are required to have a glazing strip
- The marking should be for the full width with a solid and non-transparent 75mm wide, contrasting line located 900-1000mm above FFL and provide a minimum luminance contrast of 30% when viewed against the floor surface within 2M of the glazing on the opposite end. Graphical representation or cut-outs are not permitted.

Compliance

Complies with spatial requirements

Comments

Glazing strips are required to be provided to full height glazed areas (doors and windows)
Glazing strip selections generally take place at CC stage of works. Selection of glazing strips as specified above will lead to compliance and details are to be verified at CC stage of works.

BCA Part F Accessible Sanitary Facilities

BCA 2019 Part F2.4 Accessible Sanitary facilities

Requirement

Accessible unisex toilet is to be provided in accessible part of building such that;

- It can be entered without crossing an area reserved for 1 sex only
- Where male and female sanitary facilities are provided at different locations, Accessible unisex toilet is only required at one of the locations
- Even distribution of LH and RH facilities
- An accessible facility is not required on a level with no lift / ramp access.

Compliance Complies

Comments

3 accessible toilets have been provided in the development.

BCA 2019 Part F2.4(a) Accessible unisex sanitary compartments

Requirement

Class 9b

- 1 unisex Accessible toilet on every storey containing sanitary compartments. Where more than 1 bank of sanitary compartments on a level, at 50% of banks

Compliance Complies

Comments

The following common use sanitary facilities have been identified in the development

Location	Unisex Accessible facilities			
	LH	LH + Shower	RH	RH + Shower
Unisex accessible toilet on Lower Ground Floor Level	<input type="checkbox"/>	<input checked="" type="checkbox"/>	<input type="checkbox"/>	<input type="checkbox"/>
Unisex accessible toilet on Ground Floor Level	<input type="checkbox"/>	<input checked="" type="checkbox"/>	<input type="checkbox"/>	<input type="checkbox"/>
Unisex accessible toilet on First Floor Level	<input type="checkbox"/>	<input type="checkbox"/>	<input type="checkbox"/>	<input checked="" type="checkbox"/>

BCA 2019 Part F2.4(b) Requirements for Accessible unisex showers

Requirement

Class 9b

When BCA requires provision of 1 or more showers, then 1 for every 10 showers.

Compliance Complies

Comments

The following common use sanitary facilities are provided in the development

Location	Unisex Accessible facilities			
	LH	LH + Shower	RH	RH + Shower
Unisex accessible toilet on Lower Ground Floor Level	<input type="checkbox"/>	<input checked="" type="checkbox"/>	<input type="checkbox"/>	<input type="checkbox"/>
Unisex accessible toilet on Ground Floor Level	<input type="checkbox"/>	<input checked="" type="checkbox"/>	<input type="checkbox"/>	<input type="checkbox"/>
Unisex accessible toilet on First Floor Level	<input type="checkbox"/>	<input type="checkbox"/>	<input type="checkbox"/>	<input checked="" type="checkbox"/>

Requirement

Accessible unisex toilet is to be designed in accordance with AS1428.1-2009

Compliance Complies with spatial requirements

Comments

Detailed features of the accesible toilet will be assessed at the CC stage of works

Requirement

Showers for Accessible use are to be designed in accordance with AS1428.1

Compliance Complies with spatial requirements

Comments

Detailed features of the Accessible shower will be assessed at the CC stage of works

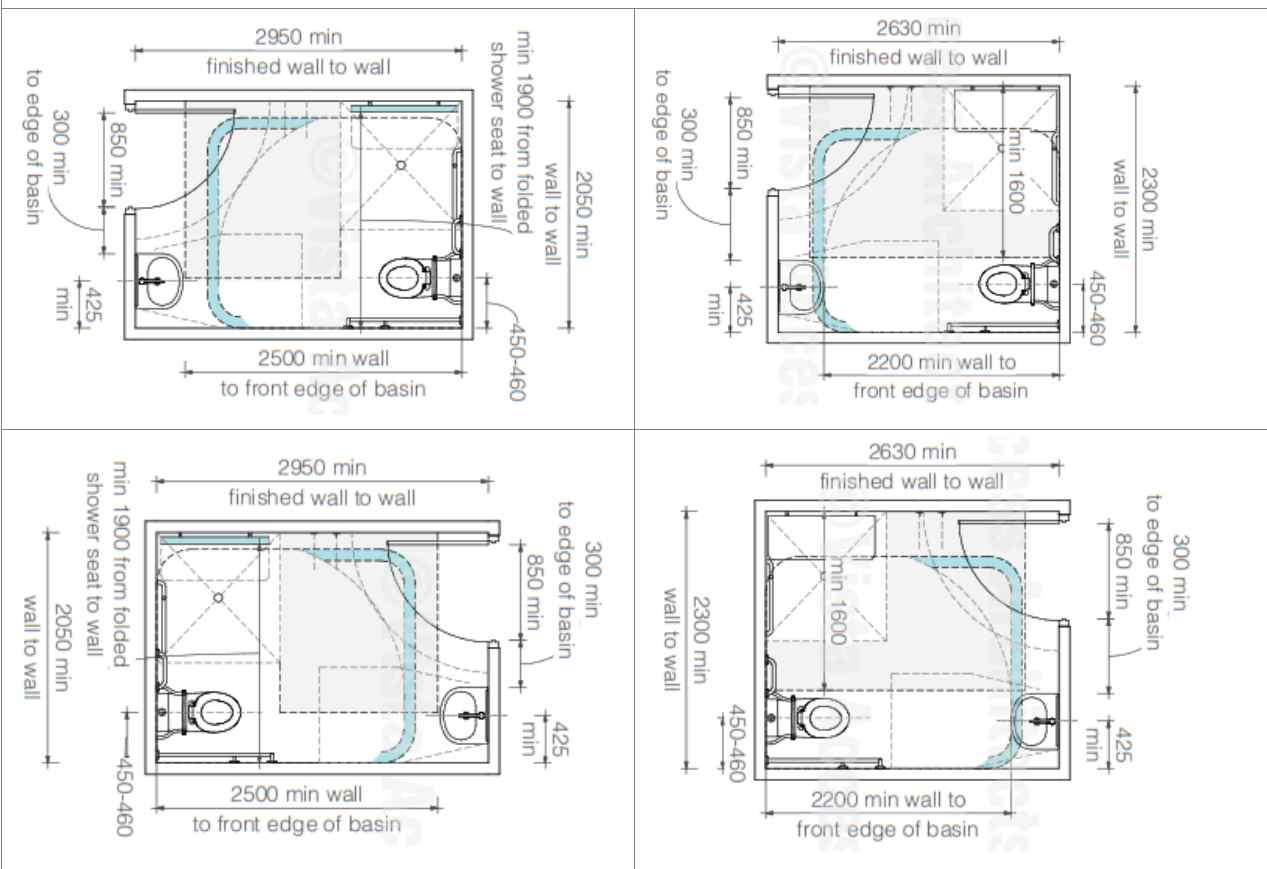

Requirement

Ambulant use male / female toilets are to be provided if an additional toilet to the Accessible unisex toilet is provided

Compliance N/A

Comments

No ambulant toilet facilities have been identified in the development

Requirement

Ambulant use toilets are to be designed in accordance with AS1428.1-2009

Compliance N/A

Comments

No ambulant toilets have been identified on the plans

BCA Part E Lift Installations

BCA 2019 Part E3.2 Stretcher facility in lifts

Requirement

A **Stretcher lift** is to be provided if a passenger lift is installed to serve any storey with an effective height of 12M. The space requirement is 600mm wide x 2000mm deep x 1400mm high above the floor level. Confirm this requirement with your BCA consultant.

Compliance For information only

Comments

Contact BCA consultant in regard to applicable requirements.

BCA 2019 Part E3.6 Passenger lift and their limitations

Requirement

In an accessible building, **Every Passenger Lift** (excluding electric passenger lift, electrohydraulic passenger lift, inclined lift) must be subject to limitations on use and must comply with **Tables E3.6a and E3.6b**

Compliance Complies with spatial requirements

Comments

A certificate of compliance from the lift supplier, stating that the proposed lift complies with the requirements of BCA Part E3- Lift installations will be required at the CC stage of works

Limitations on use of types of passenger lifts

Requirement

Limitations on use of Stairway platform lifts, Low-rise platform lift, Low-rise, low-speed constant pressure lift and small sized, low-speed automatic lift

Compliance

N/A

Comments

Not identified in the development.

BCA 2019 Part E3.6 Accessible features required for passenger lifts

Requirement

Handrail requirements for passenger lifts. Apart from stairway platform lift and low-rise lifts, a handrail is required as per AS1735.12:

- 600mm minimum handrail not more than 500mm from control panel
- Top of handrail between 850-950mm above FFL
- Diameter of handrails to be between 30-50mm and located not less than 50mm from adjacent walls with no obstructions to top 270° arc

Lift floor dimensions (excluding stairway platform lift)

- Lifts traveling **12M** or under, floor size, **1100mm wide x 1400mm deep**
Lifts travelling **more than 12M**, floor size **1400mm wide x 1600mm deep**

Minimum **Door opening size** complying with AS1735.12, not less than 900mm clear (excluding stairway platform lift).

All lifts with a power operated door are required to have a **Passenger protection system** complying with AS1735.12.

Lift landing doors to be provided at upper landing (excluding stairway platform lift).

Lift car and landing control buttons complying with AS1735.12

Some of the requirements listed below. Refer to AS1735.12 for further details.

For internal control panel:

- If width or depth of car is less than 1400mm, 2 control panels to be provided, one to the left and one to the right of the person entering the car
- Tactile symbol and Braille equivalent to be provided
- Buttons to be located between 900-1100mm above FFL
- All buttons to be 300mm from corner (near entry) and 400mm of all other corners

For external control panel:

To be located between 900-1100mm above FFL and not less than 500mm from internal corners unless otherwise permitted by AS1735.12

Lighting (for all enclosed lift cars) to be provided in accordance with AS1735.12 and AS1680. Minimum illuminance of 100 lx is required at the level of the car floor and average of 50 lx is required on the control panel surface.

To all lifts serving more than 2 levels

- Automatic audible information to identify level when car stops

- Audible and visual indication at landing to indicate arrival of lift car
Audible information and indication to be provided between 20-80 dB(A) at a maximum frequency of 1500Hz

Emergency hands free communication (excluding stairway platform lift) – provide a button that alerts a call centre and a light that the call has been received.

Compliance Complies with spatial requirements

Comments

A certificate of compliance from the lift supplier, stating that the proposed lift complies with the requirements of BCA Part E3- Lift installations will be required at the CC stage of works

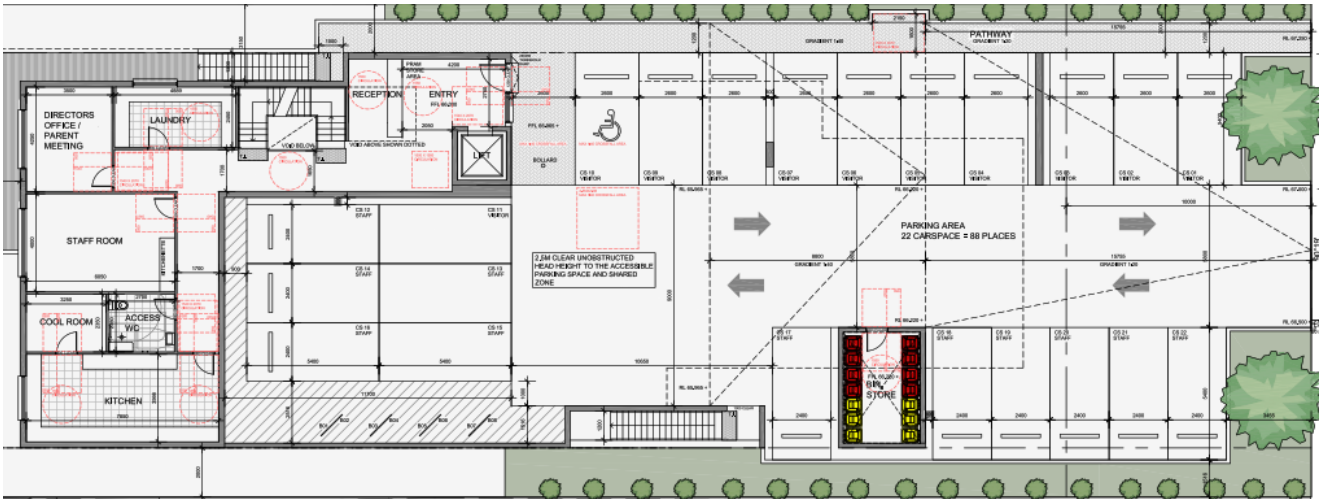

Ground

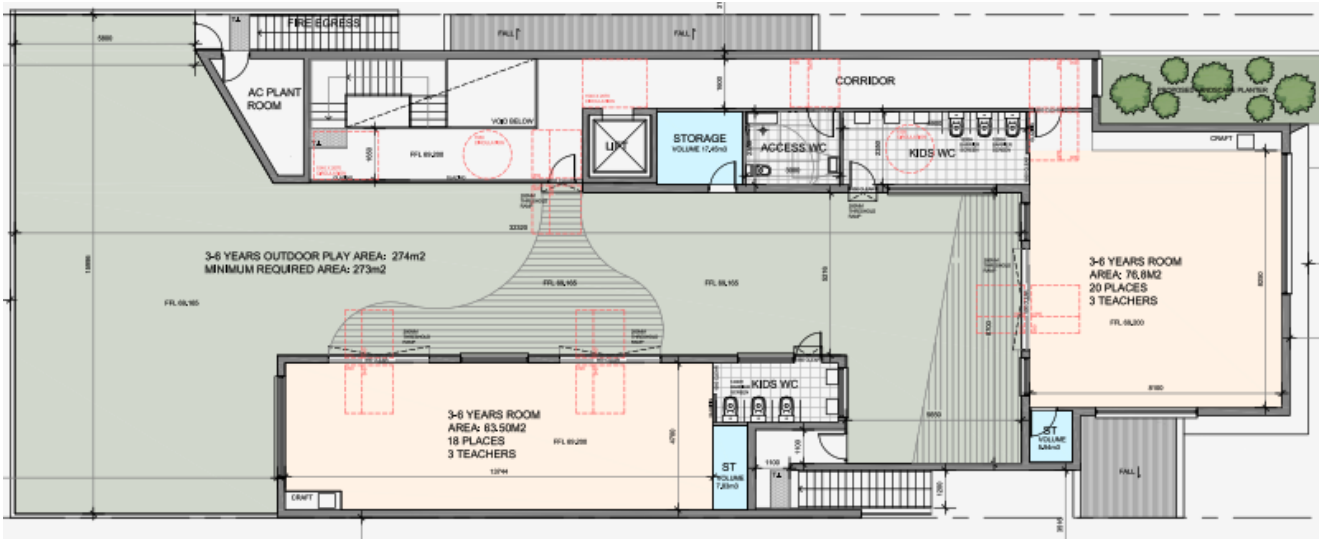

First

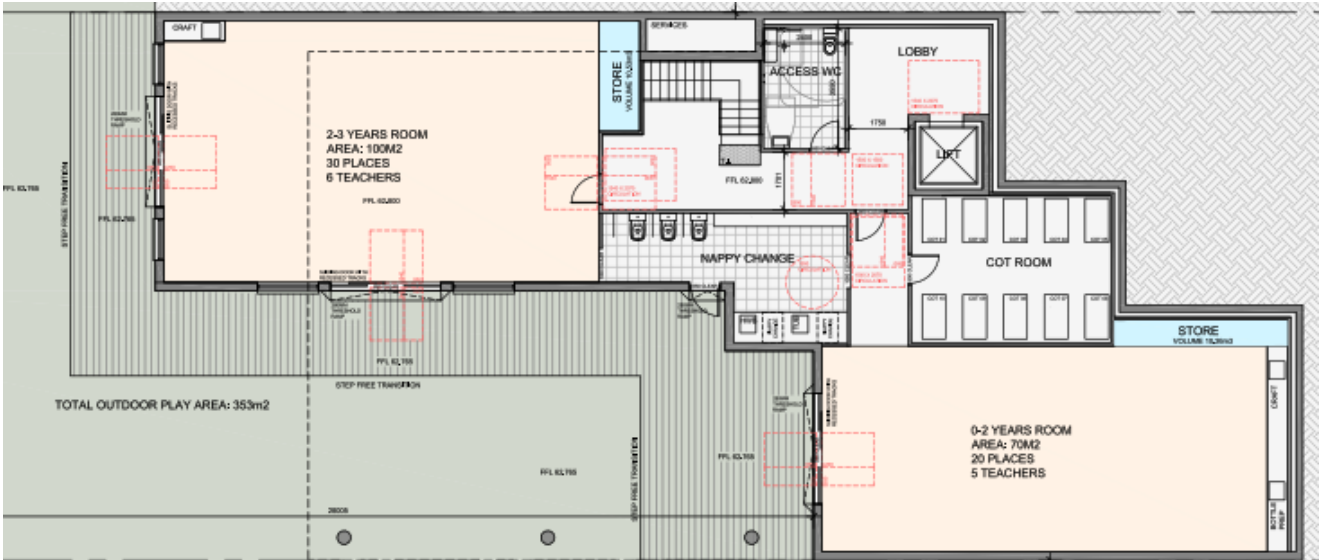

Lower ground

Statement of Experience

Vista Access Architects specialises in access consultancy services, including, Access requirements and Access Performance Solutions under the NCC, NDIS SDA Certifications, Livable Housing Certifications and Changing Places Certifications.



Farah Madon - Director

ACAA Accredited Access Consultant
NDIS Accredited SDA Assessor
Livable Housing Assessor
Changing Places Assessor

- Accredited member of the Association of Consultants in Access Australia (ACAA) - 281
- NDIS Accredited SDA (Specialist Disability Accommodation) Assessor SDA00001
- Architect registered with the NSW Architect's Registration Board - Registration 6940
- Member of Australian Institute of Architects (RAIA), A+ Practice Member 49397
- Registered Assessor of Livable Housing Australia - Registration 10032
- Global Alliance on Accessible Technologies and Environments (GAATES) - BE-02-021-20
- Registered Assessor of Changing Places Australia - Registration CP006

Farah's Educational Profile and Qualifications include:

- Bachelor of Architecture Degree with Honours (B.Arch.)
- International Certification of Accessibility Consultants – Built Environment (ICAC-BE) Program, Level 2 Advanced Accessibility Consultant
- Diploma of Access Consulting

Farah has 20 years of experience of working in the field of Architecture and Access.

Farah is the lead author of the NDIS SDA Design Standard. She has been invited on multiple occasions as an expert witness for Access related matters in the NSW Land and Environment Court.

Farah currently participates on the following key committees concerning access for people with disabilities, on an honorary basis:

- Member of Standards Australia's ME-064 Committee responsible for the AS4299 and AS1428 suite of standards.
- Vice President of Association of Consultants in Access Australia (ACAA)
- Community Representative Member of the Penrith City Council's Access Committee
- Member of Australian Institute of Architect's National Enabling Architecture Committee (NEAC)
- Management Committee member of NSW Network of Access Consultants
- Director of Livable Housing Australia (LHA)
- Member of Changing Places Australia Technical Advisory Team

Some Recent Awards presented to Farah include:

- 2021 Australian Access Awards Winner for the Educational App of the Year - SDA Tools
- 2021 Excellence in Inclusion - Altitude Awards - Winner
- 2021 Western Sydney Executive Woman of the Year - Finalist
- 2019 Penrith Citizen of the Year
- 2019 Access Inclusion Award
- 2019 Australian Access Awards Educational App of the Year - LRV Contrast App - Finalist





Vanessa Griffin

ACAA Accredited Access Consultant
NDIS Accredited SDA Assessor
Livable Housing Assessor
Changing Places Assessor

- Accredited member of the Association of Consultants in Access Australia (ACAA) - 500
- NDIS Accredited SDA (Specialist Disability Accommodation) Assessor SDA00009
- Registered Assessor of Livable Housing Australia - Registration 20035
- Registered Assessor of Changing Places Australia Registration CP010

Vanessa's Educational Profile and Qualifications include:

- Diploma of Surveying and Diploma of Health and Building Surveying, Sydney Institute of Technology
- Certificate IV in Access Consulting



Jenny Desai

ACAA Accredited Access Consultant
NDIS Accredited SDA Assessor
Livable Housing Assessor

- Accredited member of the Association of Consultants in Access Australia (ACAA) - 572
- NDIS Accredited SDA (Specialist Disability Accommodation) Assessor SDA00043
- Registered Assessor of Livable Housing Australia - Registration 20242

Jenny's Educational Profile and Qualifications include:

- Master of Design (M.Des) from University of Technology, Sydney
- Certificate IV in Access Consulting



Art Phonsawat

ACAA Associate Access Consultant

- Associate member of the Association of Consultants in Access Australia (ACAA) - 695

Art's Educational Profile and Qualifications include:

- Advanced Diploma in Interior design, Sydney
- Certificate IV in Access Consulting



Trin Woo

ACAA Affiliate Access Consultant

- Affiliate Member of the Association of Consultants in Access Australia (ACAA) - 776

Trin's Educational Profile and Qualifications include:

- Architect registered with the NSW Architect's Registration Board - Registration 11059
- Master of Urban and Regional Planning at the University of Sydney (in progress)